

**Minuteman**<sup>®</sup>  
**PowerBoss**<sup>®</sup>

# Armadillo<sup>®</sup> SW/5X

40" Compact Industrial Sweeper



**Variable high dump  
or low dump options  
available on all 5X  
series sweepers.**

**Optional dual side broom shown.**

The Minuteman PowerBoss 5X Rider Sweeper is designed for heavy-duty industrial use. It is constructed on a steel frame and the panels, made of a synthetic material, are practically indestructible. With a 70" (180 cm) and 90-90 turning radius, it is extremely maneuverable as a result of the directly steered front wheel drive, making it easy to operate even in the narrowest of aisles.

The Minuteman PowerBoss 5X Rider Sweeper comes standard with a single side broom, with optional left side broom. It provides perfect sweeping results due to the large, newly developed main broom with compensation for wear and tear. It comes in gas, propane, or battery and is available with either a hydraulic high dump that extends up to 60" (152cm) or a manual low dump hopper.

**Direct Access**

The engine or battery compartment is clearly laid out and directly accessible for maintenance and servicing purposes. The seat console simply tilts backwards to reveal the compartment. The seat is also equipped with a safety shut-off switch. If the operator gets up from the seat, the machine will shut down.



**Robust Main Broom System**

The large, newly developed main broom with wrap-around protection and patented broom holder can be changed without tools.



**User-Friendly Control Panel**

The center console is designed for ease of use with easy to understand controls for simple operation.



**Central Sweeping Level Adjustment**

This guarantees that the right level and even pressure is exerted by the suspended main broom.

Specifications for Gas, LP, or Battery Models	
Sweeping width (2 side brooms) <i>optional</i>	47" (119 cm)
Sweeping width (1 side broom)	40" (100 cm)
Main Broom Length	28" (71 cm)
Performance (2 side brooms)	77,500 sq ft / hr (7200 sq m / hr)
Performance (1 side broom)	61,354 sq ft / hr (5700 sq m / hr)
Low Dump Hopper Volume	2.1 cubic ft. (60 liters)
High Dump Hopper Volume	2.1 cubic ft. (60 liters)
Dust Control Filter Area	30.14 cubic ft. (2.8 sq. m.)
Multi Level Dump Clearance	60" (152 cm)
Engine	8 HP Kawasaki
Turning Radius	70" (178 cm)
Sweeping Speed	4 mph
Climbing Ability	9 degrees (16%)
Length with Side Broom	59" (150 cm)
Width	50" (127 cm)
Height	52" (132 cm)
Weight (Gas or LP)	772 lbs (350 kg)
Weight with Batteries(24v battery system)	970 lbs (440 kg)

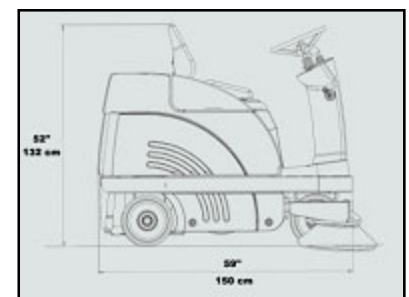
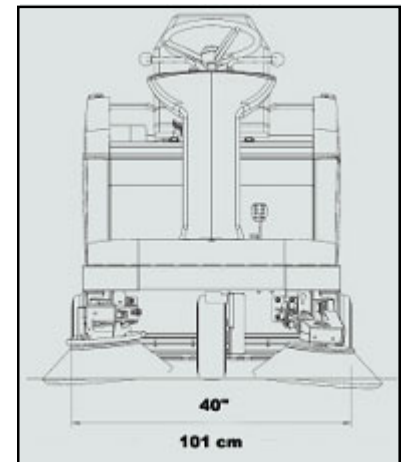

**World Headquarters**  
**Minuteman International, Inc.**  
 111 South Rohlwing Road • Addison, IL 60101-4244  
 Telephone: (630) 627-6900 • Fax: (630) 627-1130  
 www.minutemanintl.com

**Minuteman PowerBoss**  
 175 Anderson Street • Aberdeen, NC 28315  
 Telephone: (910) 944-2105 • Fax: (910) 944-7409  
 www.powerboss.com

Minuteman is a full line manufacturer of maintenance products including critical filter vacuums, industrial and commercial vacuums, sweepers, scrubbers, floor and carpet machines, PowerBoss® sweepers and scrubbers, Parker Sweeper® Litter Vacs and Multi-Clean® chemicals for industrial, commercial, and institutional facilities.